

# 800112-MPX

## Light harness installation instructions

(Module installed in the front – on the plow)

F250/350450/550 (2023 Halogen lights)

Recommended Fuse on Vehicle's Ignition Panel for 2020 and newer trucks, Use Fuse number 6 allocated for Snowplowing 10A



# Body Builders Layout Book

## ALL SUPER-DUTY FUSE LAYOUT – PDB / HCFB

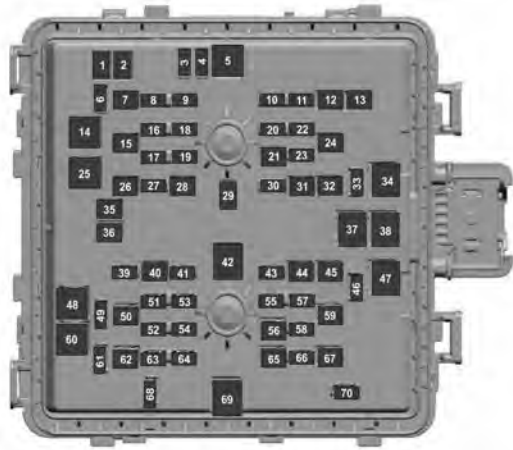

| Fuse Number | Fuse Rating | Protected Component   |
|-------------|-------------|---|
| 1           | 20 A        | Power point 4.  |
| 2           | 20 A        | Power point 3.  |
| 3           | 10 A        | Spot light module.  |
| 4           | 10 A        | Four-wheel drive vacuum solenoid.                             |
| 5           | 40 A        | Active front steering.  |
| 6           | 10 A        | Snow plow.  |
| 7           | 30 A        | Trailer tow battery charge.                                   |
| 8           | 10 A        | Anti-lock brake system module.                                |
| 9           | 10 A        | Electronic power assisted steering module.                    |
| 10          | 30 A        | Trailer tow park lamps.                                       |
| 11          | 20 A        | Horn.   |
| 12          | 30 A        | Torque overlay.   |
| 13          | 30 A        | Power sliding rear window.                                    |
| 14          | 40 A        | Body control module - battery power in feed 1.                |
| 15          | 30 A        | Passenger seat power.   |
| 16          | 10 A        | Powertrain control module. Transmission control module.       |
| 17          | 10 A        | Blind spot information system.                                |
| 18          | 10 A        | Four-wheel drive module.                                      |
| 19          | 5 A         | Adaptive cruise control.                                      |
| 20          | 15 A        | Heated mirrors.   |
| 21          | 40 A        | Heated rear window.   |
| 22          | 10 A        | On-board diagnostic module. Smart data link connector.        |
| 23          | 15 A        | Transmission control module.                                  |
| 24          | 30 A        | Driver power seat.  |
| 25          | 25 A        | Voltage quality module.                                       |
| 26          | 30 A        | Trailer tow battery charge.                                   |
| 27          | 20 A        | Rear heated seats.  |
| 28          | 25 A        | Glow plug (diesel).   |
|             | —           | Not used (gas).   |
| 29          | 40 A        | Electric power assisted steering motor.                       |
| 31          | 20 A        | Power point 5.  |
| 32          | 25 A        | Four-wheel drive module.                                      |
| 33          | 10 A        | Alternator sense line 2.                                      |
| 34          | 50 A        | Electric cooling fan (gas). Supplemental air heater (diesel). |
| 35          | 20 A        | Power point 2.  |

Note: Spare fuse amperage may vary.

| Fuse Number | Fuse Rating | Protected Component   |
|-------------|-------------|---|
| 36          | 20 A        | Power point 1.  |
| 37          | 60 A        | Anti-lock brake system pump.  |
| 38          | 60 A        | Inverter.   |
| 39          | 25 A        | Four-wheel drive module.  |
| 40          | 30 A        | Starter motor solenoid.   |
| 41          | 10 A        | Tailgate release solenoid.  |
| 42          | 40 A        | Blower motor.   |
| 43          | 10 A        | Trailer tow backup lamps.   |
| 44          | 40 A        | Trailer tow lighting module.  |
| 45          | 30 A        | Anti-lock brake system valve.   |
| 46          | 30 A        | Compressed natural gas module power.  |
| 47          | 50 A        | Supplemental air heater (diesel).   |
|             | —           | Not used (gas).   |
| 48          | 50 A        | Supplemental air heater (diesel).   |
|             | —           | Not used (gas).   |
| 49          | —           | Not used.   |
| 50          | 30 A        | Heated and cooled seats.  |
| 51          | 20 A        | Powertrain control module.  |
| 52          | 15 A        | Compressed natural gas (gas).<br>Fuel rail pressure relief control (diesel).  |
| 53          | 20 A        | Exhaust gas recirculation stepper motor (gas).<br>Universal exhaust gas oxygen sensors (gas). Exhaust gas<br>recirculation cooler bypass (diesel).<br>Urea pump motor controller (diesel).<br>Oxygen sensors. |
| 54          | 20 A        | A/C clutch relay power.<br>Fan clutch.  |
| 55          | 5 A         | Rain sensor.  |
| 56          | 30 A        | Windshield wipers.  |
| 57          | 10 A        | Upfitter interface module.  |
| 58          | 10 A        | Alternator sense line.  |
| 59          | 30 A        | Power running boards.   |
| 60          | 40 A        | Body control module - battery power in feed 2.  |
| 61          | 10 A        | Telescopic mirror motors.   |
| 62          | 40 A        | Trailer brake control. Aftermarket e-brake access.  |
| 63          | 15 A        | Multi-contour seats.  |
| 64          | 20 A        | Ignition coil (gas).<br>Glow plug module (diesel). Nitrogen oxide module (diesel).<br>Urea level and quality sensor (diesel).   |
| 65          | 30 A        | Fuel pump.  |
| 66          | 10 A        | A/C clutch solenoid.  |
| 67          | 40 A        | Auxiliary lighting module.  |
| 68          | 10 A        | Powertrain control module.  |
| 69          | 60 A        | Body control module power.  |
| 70          | 30 A        | Trailer tow stop and turn lamps.  |

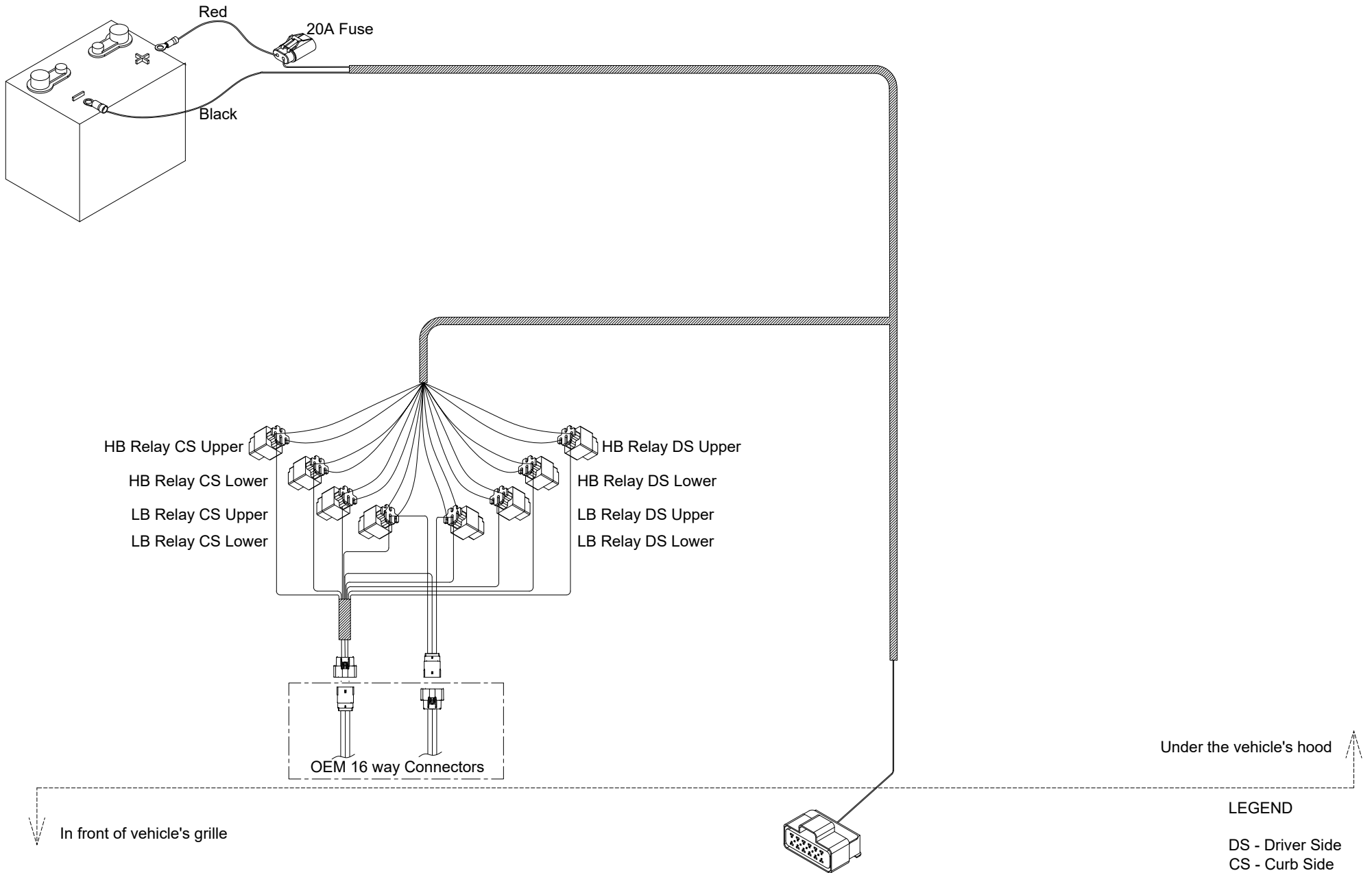

### Installation instructions

**Warning:**

- Top of battery needs to be protected. If positive side of battery is accidentally grounded person could be burnt or wiring system can be damaged, or battery gases could explode causing injuries.
- Disconnect cable from negative battery terminal before starting installation.
- Always wear eye protection and protective clothing when working around hydraulic systems.
- Remove jewelry and objects that might conduct electricity while working on power units.
- Electrical cables (harnesses) must be tied and routed safely to avoid any damage and pinching (away from hot places, sharp objects etc.).
- When drilling mounting holes or using self-tapping screws in the engine compartment, be sure to check the mounting location for any wires, hoses other obstructions that could be damaged during installation.

1. Turn off the ignition of your vehicle.
2. Disconnect the negative battery cable of vehicle.
3. Use dielectric grease on all electrical connections to prevent corrosion.
4. Remove the air filter on passenger side.
5. To access OEM 16-way connectors (picture 1), remove the bracket (picture 2) that is attached to passenger side vehicle fender.



Picture 1



Picture 2

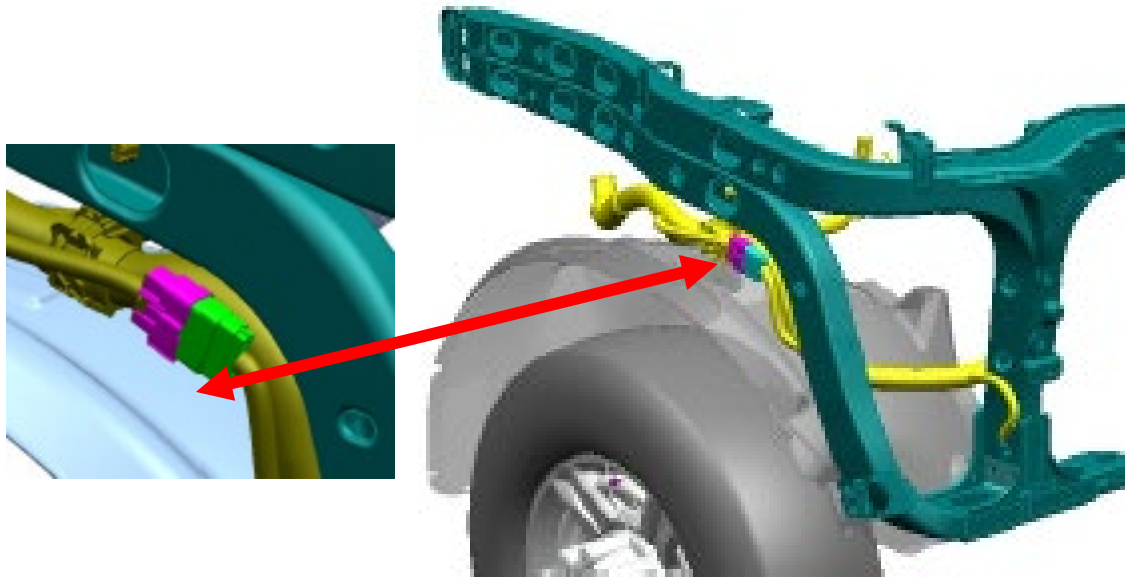

6. Install the light harness 800112-MPX avoiding any sharp edges, any moving or hot parts. Use cable ties to safely secure the harness.
7. Connect plugs from 800112-MPX to the mating connector on OEM harness.
8. Make sure that relay terminals are very well greased & placed in a safe position away from hot or moving parts.
9. Make sure that 12-way connector (see picture below) from the light harness comes out on the driver side from the vehicle grill.

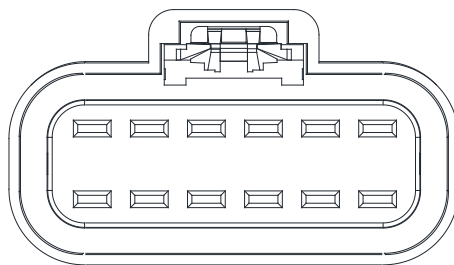

10. Attach red wire to the positive side and white/black & black wire to negative side of the battery (see below).

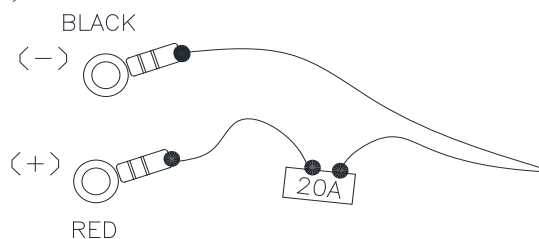

11. Install vehicle parts previously removed (air filter).
12. Snowplow Lamps should be mounted in the desired location on the snowplow frame ensuring that the snowplow lamp beams are not obstructed by any portion of the plow or vehicle.
13. After installation of the light harness, main control harness, all cables and wiring, install a snowplow headlight and check for proper operation of the light.
14. Parking & turn lamps should be on at same time as vehicle parking & turn lamps. If any lamp does not operate correctly, re-check wiring against wiring diagram and make necessary corrections in wiring hookup. Adjust the plow lamp beams to project the same distance ahead of the vehicle as compared to the original headlights.
15. Installer of these snowplow lamps must certify that installation conforms to applicable Federal Motor Vehicle Safety Standards.

Arctic Equipment Manufacturing Corporation reserves the right under its product improvement policy to change construction or design details and furnish equipment when so altered without reference to illustrations or specifications used.