

# Mounting Kit 53996-MKPB-QLIV

W4500/5500 (4x4), (4x2) 2019-2024

For the snowplow lights (2019 and above), this kit requires:  
800084 or 800086 light kit,  
800089-MPX light adapter.

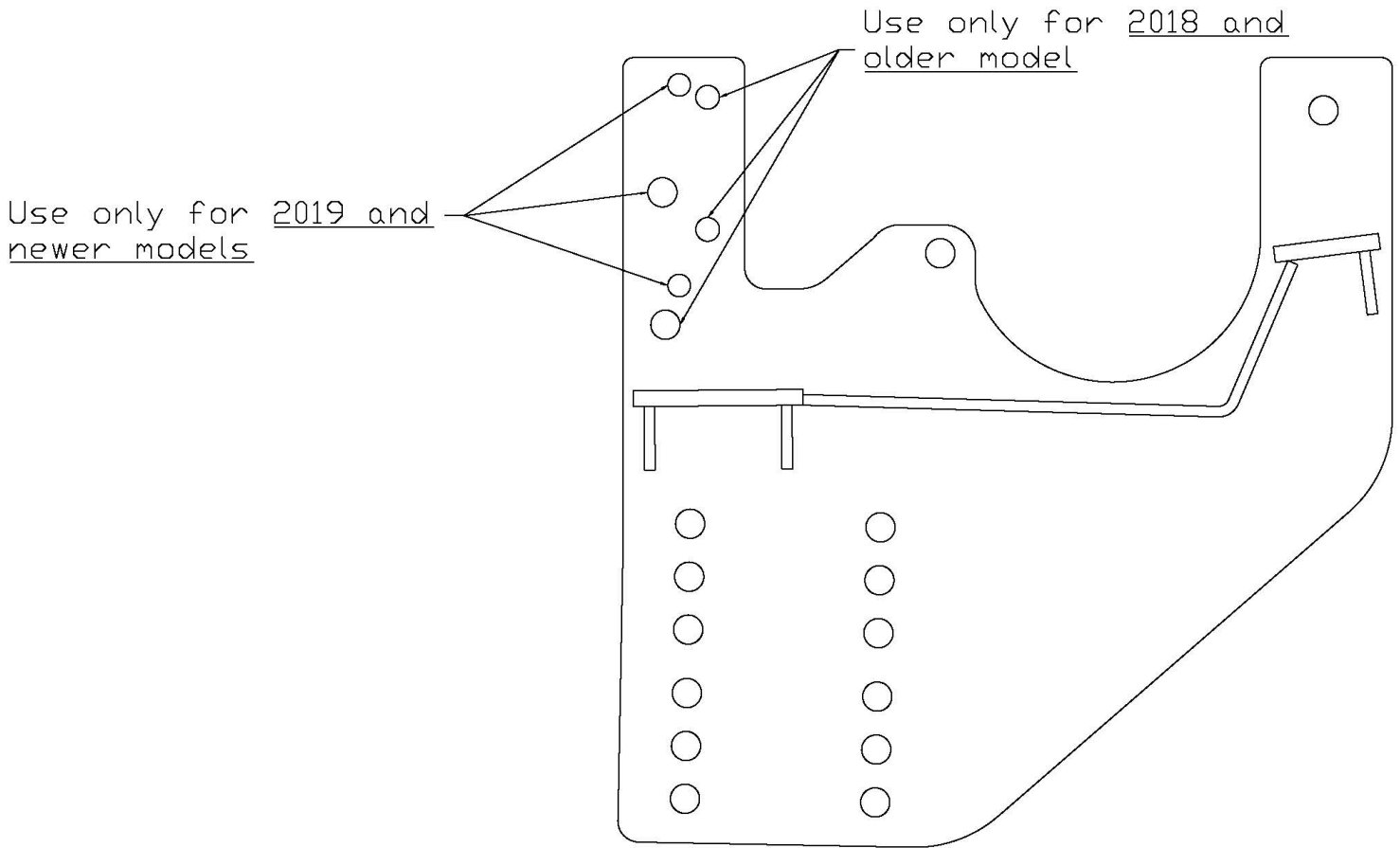

Side View of Mounting Bracket (16) (17)

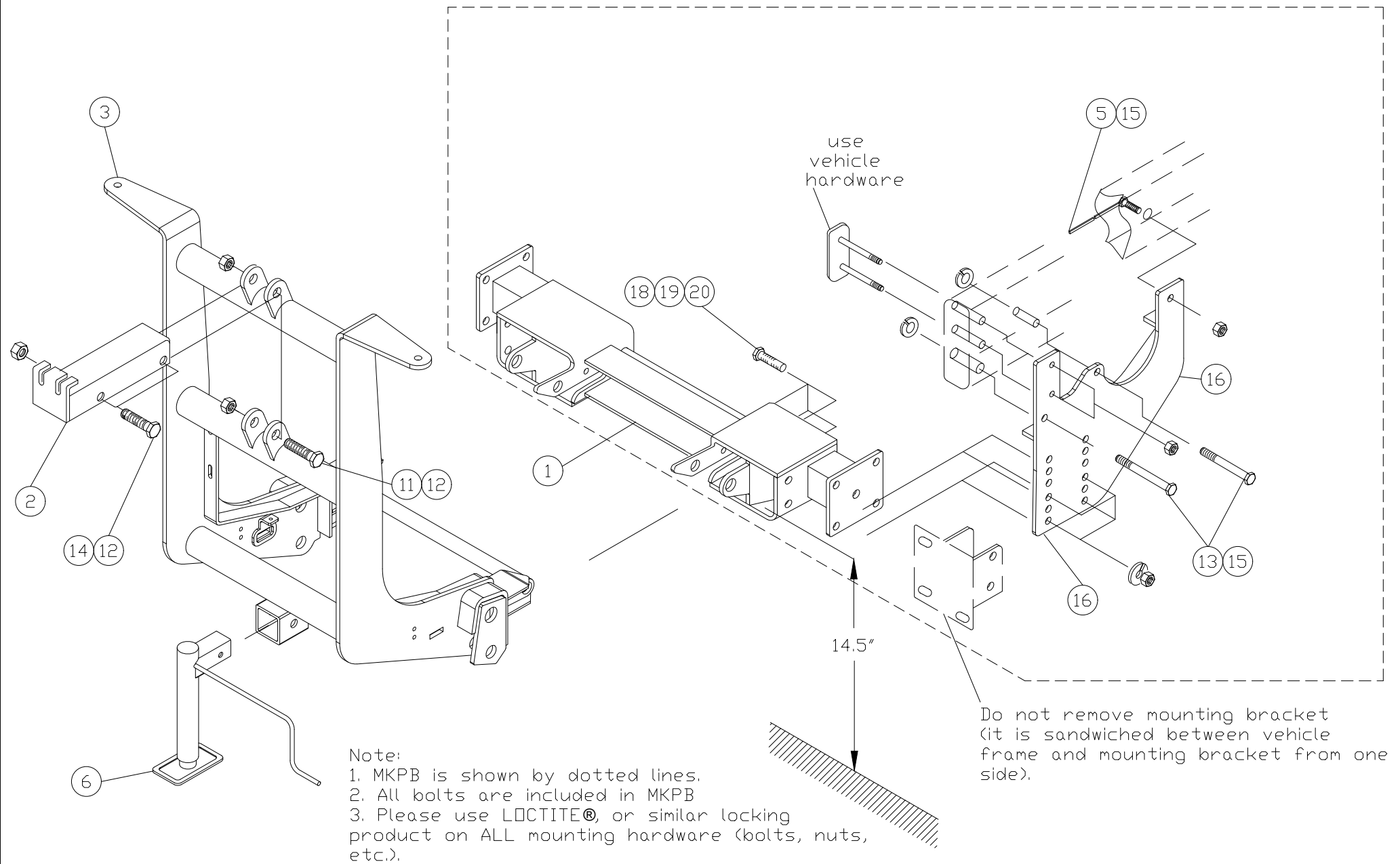

Note:  
 1. MKPB is shown by dotted lines.  
 2. All bolts are included in MKPB  
 3. Please use LOCTITE®, or similar locking product on ALL mounting hardware (bolts, nuts, etc.).

Do not remove mounting bracket (it is sandwiched between vehicle frame and mounting bracket from one side).

53996-MKPB-QLIV			
Item	Part number	Description	Quantity
1	53299-05-D	Spreader Bar QLIV	1
2	52612-B-GA	Lift Channel (2" cylinder)	1
3	53171-D-GA	Lift Frame, QUIK*LINK ® III-Hi boy	1
4	52348-M	Mounting Pin, Ass'y	2
5	52575-11-A	5/8" Welded Bolt 18" handle	2
6	52373-M	Jack Assembly	1
7*	HH-00972-090	½" x 1 ½" UNF Hex Head Cap screw	6
8*	HH -00457-001	½" Lock washer	6
9*	HH-00460-002	½" UNF Nut	6
10*	HH-00972-149	¾" x 2 ½" UNF Hex Head Cap screw	1
11	HH-00972-153	¾" x 3 ½" UNF Hex Head Cap screw	2
12	HH-00973-007	¾" UNF Thin Collar Locknut	3
13	HH-01081-138	5/8" x 4" UNC Hex Head Cap screw gr. 8	4
14	HH-00972-155	¾" x 4" UNF Hex Head Cap screw	1
15	HH-01050-020	5/8" Nylon Insert UNC Grade 8	6
16	53428-01-B	Mounting Bracket, Driver Side	1
17*	53428-02-B	Mounting Bracket, Curb Side	1
18	HH-00972-129	5/8" x 1 ¾" UNF Hex Head Cap screw	8
19	HH-00457-003	5/8" Lock washer	8
20	HH-00460-001	5/8" Hex Nut	8
21*	HH-00293-006	1/4"x1" UNC Hex Head Cap screw	4
22*	HH-00341-002	1/4" Flat washer	4
23*	HH-00457-006	1/4" Lock washer	4
24*	HH-00294-001	1/4" Hex Nut	4
* These items are not shown in the drawing			

**▲ Warning**

Arctic Equipment Manufacturing Corporation (Arctic) does not assume liability for damage to your motor vehicle resulting from the attachment or use of an Arctic snowplow. The purchaser assumes all vehicle risk associated with the attachment and operation of this snowplow.

The Arctic snowplow you purchase must be used only on vehicles equipped with the manufacturer's snow plow preparation packages. Snow plowing without the original plow preparation package may damage your vehicle. The added weight may impair the operation and control of your vehicle. Snow plowing with a vehicle not recommended for that purpose by the manufacturer may void your new vehicle warranty. If your vehicle is not equipped with an original snow plow preparation package, additional equipment may be necessary before snow plowing. Please consult your vehicle and snowplow dealers prior to the purchase and installation of the snowplow. The installation of such parts however is not a full substitute for the original equipment snowplow preparation package.

The loaded vehicle, including all aftermarket accessories, the snowplow, passengers and cargo, must not exceed the gross vehicle weight ratings (GAWR), front gross axle weight rating (FGAWR) or rear gross axle weight rating (RGAWR) specified on the Safety Compliance Certification Label located in the driver's side door opening. It is the operator's responsibility to verify that these rating are not exceeded. The use of rear ballast weight may be required to prevent exceeding the front GAWR.

To determine the Gross Axle Weights for your vehicle, including all aftermarket accessories, the snowplow, passengers and cargo, take your loaded vehicle and the snowplow to a scale. With the snowplow attached, place the front wheels of the vehicle on the scale to get the front gross axle weight (FGAW). To get the rear gross axle weight (RGAW), place the back wheels of the vehicle on the scale.

## Installation Instructions

Before drilling any holes in the firewall or frame, move brake lines, fuel lines and/or electrical wiring from the path of the drill. Brake and fuel lines must also be clear of any fasteners.

Do not under any circumstances disable, remove or relocate any sensors or other components related to the operation of the air bags.

General order of installation:

- install all components (mounting bracket, thrust arm and spreader bar) and all fasteners finger tight (snug) through existing holes,
- use removable grade LOCTITE #242 on all bolts,
- drill necessary holes and
- tighten all hardware.

After first use, retighten all mounting bolts, thereafter check mounting bolt tightness periodically and at the start of the season.

Before proceeding, read instructions carefully and familiarize yourself with the components and hardware.

NOTE: It may be necessary, on some vehicles, to use a form of load booster to decrease the vehicle's front suspension sag when snowplows is attached to the vehicle. This can be done with the use of, booster springs, supplementary air bags or similar load boosting devices. It is up to the customer to choose and purchase the product that suits this application.

Arctic Equipment Manufacturing reserves the right, under its product improvement policy, to change construction, design details or specifications without notice or without incurring any obligation

1. Remove bumper (bumper is held to bumper mounting bracket by 2 bolts on each side). If there are tow hooks, both of them need to be removed (each tow hook is attached by 2 bolts). Do not reinstall tow hooks on the truck.

2. Do not remove bumper mounting bracket. Remove ½" nuts that are holding bumper mounting bracket and install a mounting bracket (16) (17) (it is installed outside of vehicle frame (sitting on bumper mounting bracket). Secure it with nuts that were holding bumper mounting bracket.

Insert 5/8" x 4" bolt (13) through the bottom hole and hole that is in the middle, in the mounting bracket (16) (17) and secure it with nylon nut (15). Open back hole in the frame to accept 5/8" bolt. Insert 5/8" bolt with welded handle (5) through frame and secure with 5/8" nylon insert (15).

3. Install spreader bar (1) and secure it using 5/8"x 1 ¾" (18) bolts, lock washers and nuts (19) (20).

4. Torque all fasteners using torque chart. Reinstall bumper as high as possible.

5. Install lift frame (3). Slide inside of spreader bar (1). Insert mounting pin (4) in top holes of spreader bar (1).
6. Fasten lift channel (2) and lift cylinder to the lift frame (3) using 3/4"x3 1/2" bolts (11) and 3/4" lock nut (12). Use 3/4"x 4" bolt (14) and 3/4" lock nut (12) to attach lift cylinder to lift channel (2). NOTE: *Do not over tighten as this assembly must be able to pivot.*
7. Use 1/4"x1" bolt (25), 1/4" flat washer (26), 1/4" lock washer (27) and 1/4" hex nut (28) to fasten blade guides to plow.
8. Return any unused items to the customer so that the vehicle can be returned to its original condition if the snowplow is removed.
9. See separate installation instructions for the hydraulic pump, wiring and controls

Suggested torque value for bolts				
Thread Size	Grade 5		Grade 8	
	Dry (ft. lb)	Oiled (ft.lb)	Dry (ft. lb)	Oiled (ft.lb)
1/4-20	8	6	12	9
1/4-28	10	7	14	11
5/16-18	17	13	24	18
5/16-24	19	15	27	21
3/8-16	31	24	44	34
3/8-24	35	27	49	38
7/16-14	49	38	70	54
7/16-20	55	42	78	60
1/2-13	75	58	105	82
1/2-20	85	65	120	90
5/8-11	150	115	210	165
5/8-18	170	130	240	185
3/4-10	270	205	375	290
3/4-16	295	230	420	320
7/8-9	395	305	605	455
7/8-14	435	335	670	515
1-8	590	455	905	695
1-14	660	510	1030	785

Arctic Equipment Manufacturing Corporation reserves the right under its product improvement policy to change construction or design details and furnish equipment when so altered without reference to illustrations or specifications used herein.