

Mounting Kit 53247-MKPB-QLIV

K1500 Sierra/Silverado 4x4 2007-2018

- For Snowplow lights (2007-2013) it requires:
 - 800084, 800085 or 800086 Light kit,
 - 53617-M wiring kit and Adapter 800034 (vehicle's bulb H13) - GMC Yukon/Denali,
 - 800042 (vehicle's bulb H9005 (HB3) and H11) - Chevy Silverado, Tahoe, Avalanche, Suburban, GMC Sierra).

- Snowplow lights for model above 2014, this kit require:
 - 800084,800085 or 800086 Light kit,
 - 800087-MPX light adapter for Front Install (2014-2015),
 - 800090-MPX light adapter for Front Install (2016-2018).

See page #13 for UI technical bulletin #124h for Intermittent Cluster, Radio and HVAC Display resets on trucks having Snow plow installed.

▲ Warning

Arctic Equipment Manufacturing Corporation (Arctic) does not assume liability for damage to your motor vehicle resulting from the attachment or use of an Arctic snowplow. The purchaser assumes all vehicle risk associated with the attachment and operation of this snowplow.

The Arctic snowplow you purchase must be used only on vehicles equipped with the manufacturer's snow plow preparation packages. Snow plowing without the original plow preparation package may damage your vehicle. The added weight may impair the operation and control of your vehicle. Snow plowing with a vehicle not recommended for that purpose by the manufacturer may void your new vehicle warranty. If your vehicle is not equipped with an original snow plow preparation package, additional equipment may be necessary before snow plowing. Please consult your vehicle and snowplow dealers prior to the purchase and installation of the snowplow. The installation of such parts however is not a full substitute for the original equipment snowplow preparation package.

The loaded vehicle, including all aftermarket accessories, the snowplow, passengers and cargo, must not exceed the gross vehicle weight ratings (GAWR), front gross axle weight rating (FGAWR) or rear gross axle weight rating (RGAWR) specified on the Safety Compliance Certification Label located in the driver's side door opening. It is the operator's responsibility to verify that these rating are not exceeded. The use of rear ballast weight may be required to prevent exceeding the front GAWR.

To determine the Gross Axle Weights for your vehicle, including all aftermarket accessories, the snowplow, passengers and cargo, take your loaded vehicle and the snowplow to a scale. With the snowplow attached, place the front wheels of the vehicle on the scale to get the front gross axle weight (FGAW). To get the rear gross axle weight (RGAW), place the back wheels of the vehicle on the scale.

Installation Instructions

Before drilling any holes in the firewall or frame, move brake lines, fuel lines and/or electrical wiring from the path of the drill. Brake and fuel lines must also be clear of any fasteners.

Do not under any circumstances disable, remove or relocate any sensors or other components related to the operation of the air bags.

General order of installation:

- install all components (mounting bracket, thrust arm and spreader bar) and all fasteners finger tight (snug) through existing holes,
- use removable grade LOCTITE #242 on all bolts,
- drill necessary holes and
- tighten all hardware.

After first use, retighten all mounting bolts, thereafter check mounting bolt tightness periodically and at the start of the season.

Before proceeding, read instructions carefully and familiarize yourself with the components and hardware.

NOTE: It may be necessary, on some vehicles, to use a form of load booster to decrease the vehicle's front suspension sag when snowplows is attached to the vehicle. This can be done with the use of, booster springs, supplementary air bags or similar load boosting devices. It is up to the customer to choose and purchase the product that suits this application.

Arctic Equipment Manufacturing reserves the right, under its product improvement policy, to change construction, design details or specifications without notice or without incurring any obligation

Bumper removal for 2014 and newer models

1. Remove the "the air dam"



2. Remove the top cover from the of the engine compartment.



3. Remove 4 screws



4. Remove four screws attaching the grill to the rad support (4 screws are located under the bumper in approximate location shown on the picture).



5. Remove the two bumper cover screws (see picture below) located on the inside of each front wheel well. If the vehicle is furnished with fender trim, it will need to be displaced in order to access the screws.



6. Release the hidden locking tabs on each side of the vehicle and pull the bumper cover outward.



7. Pull the bumper cover assembly forward to disengage grille tabs and remove the grille.



8. Remove the four main bumper fasteners and the single fastener securing the bumper ends to the outer bumper supports. Remove the bumper.
9. Remove the center plastic part.



10. Cut inside steel support as shown below.



Inside steel support after.



11. Cut bottom “Splash Guard” to clear Trust Arms



11. Cut a bumper as shown

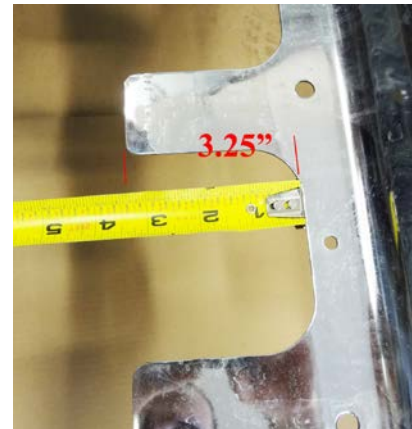
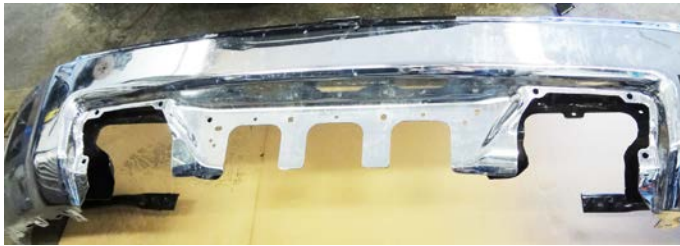

12. Chevy



GMC



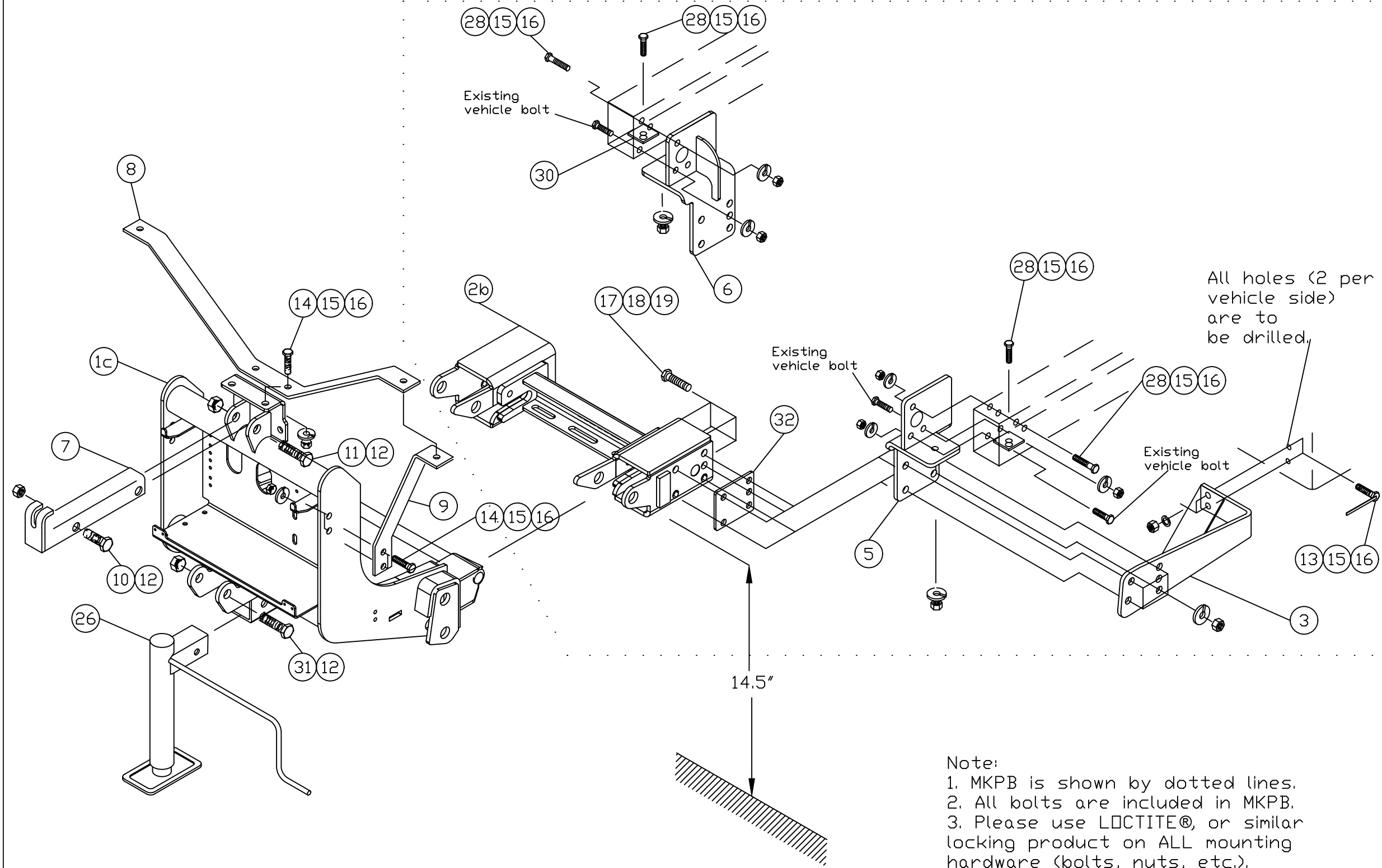

53247-MKPB-QLIV			
Item	Part #	Description	Quantity
1a*	53170-D-GA	Lift Frame, QUIK*LINK ® II- Low Mount	1
1b*	53171-D-GA	Lift Frame, QUIK*LINK ® II- Hi boy	1
1c	53564-D	Lift Frame, QUIK*LINK ® IV-Low Mount	1
1d*	53517-D	Lift Frame, QUIK*LINK ® IV- Hi boy	1
2a*	52363-C	Spreader Bar QLII	1
2b	53551-C	Spreader Bar QLIV	1
3	53252-01-B	Thrust Arm, Driver Side	1
4*	53252-02-B	Thrust Arm, Curb Side	1
5	53248-01-B	Mounting Bracket, Driver Side	1
6	53248-02-B	Mounting Bracket, Curb Side	1
7	50069-C-GA	Lift Channel Galvanized	1
8	52209-B-GA	Light Antler Galvanized	1
9	52208-B-GA	Light Brace Galvanized	2
10	HH-00972-149	3/4" x 2 1/2" UNF Cap screw	1
11	HH-00972-153	3/4" x 3 1/2" UNF Cap screw	1
12	HH-00973-007	3/4" UNF Thin Collar Lock nut	3
13	52575-A	1/2" bolt with 6" welded handle	4
14	HH-00972-090	1/2-20x1.1/2 UNF Cap screw	6
15	HH-00460-002	1/2-20 Hex nut	16
16	HH-00457-001	1/2 Lock washer	16
17	HH-00972-131	5/8-18 x 2 1/4 UNF Cap screw	8
18	HH-00457-003	5/8 Lock washer	8
19	HH-00460-001	5/8-18 Hex nut	8
20*	HH-00293-006	1/4" x 1" Cap screw	4
21*	HH-00457-006	1/4" Lock washer	4
22*	HH-00341-002	1/4" Flat washer	4
23*	HH-00294-001	1/4" Hex nut	4
25*	52348-M	Mounting Pin Ass'y	2
26	52373-M	Jack Assembly	1
27*	50999-B	Blade guides	1
28	HH-00972-091	1/2-20x1 3/4 UNF Cap screw	5
30	52569-A	Frame Plate	2
31	HH-00972-155	3/4" x 4" UNF Cap screw	1
32	53705-M	1/4" Spacer	2

QUIK*LINK is a trademark of Arctic Equipment Manufacturing Corporation

* These items are not shown on the drawing.

Installation Instructions

1. For the bumper removal on 2014 and newer truck models only, refer to instructions above.
For models prior to 2014 models remove the bumper and bottom splash pan (skid plate). Do not remove tow hooks. Note: After installation of mounting kit and spreader bar, bumper is going to be reinstalled and bottom plastic part of bumper needs to be cut as shown on the picture below.
2. Loosen bolts that are holding tow hooks and remove bracket with two studs (this bracket is not going to be used). Bolts for tow hooks must be turned so that nut is inside. Install mounting brackets as shown using two existing vehicle bolts on driver side and one existing vehicle bolt on curb side. Instead of using bracket with two studs, use ½" x 1 3/4" bolts (28), ½" lock washers (16) and ½" hex nuts (15). Do not tighten any hardware until instructed to do so.
3. Insert the spreader bar (2b) between mounting brackets (5) and (6) Place ¼" Spacer (32) on both the sides in between spreader bar (2b) and mounting brackets (5) and (6). Insert 5/8" x 2" bolts (17) from inside spreader bar (2b), passing to the spacer (32) through mounting bracket holes.
4. Install thrust arm (3)(4) (note thrust arm must be installed as shown on the picture with gusset on the top of thrust arm) to the mounting bracket using 5/8" bolt (17), 5/8" lock washer (18) and 5/8" nut (19). Ensure that thrust arms are tight against cross member before drilling 17/32" hole, using 9/16" holes in thrust arm as guide. Insert ½" welded bolt (13) from inside the frame, through the thrust arm (3)(4). Secure using ½" lock washers (16) and ½" hex nuts (15).
5. Drill hole on the bottom of mounting bracket and install ½" x 1 3/4" (28) bolt. Before installing bolt insert frame plate (30). Secure bolt with ½" lock washer (16) and ½" hex nut (15). It will be necessary to remove front tow hook bolt to do so.
6. Torque all fasteners according to torque chart.
7. Reinstall the bumper. Do not reinstall a splash pan. Modify and reinstall a splash pan for 2014 and up models.
8. Install the lift frame (1c). Slide inside of spreader bar (2b).
9. Install light antler (8) and light braces (9) using ½" x 1½" bolts (14), ½" lockwashers (16) and ½" hex nuts (15). Install lights so that the light mounting stud goes through both antler (8) and the brace (9). Tighten all light mounting hardware.
10. Install lift channel (7) and front mount pump (from hydraulic kit) or hydraulic cylinder to

lift frame (1c) using 3/4" x 3½" bolts (11) and 3/4" locknuts (12). Use 3/4" x 2½" bolt (10) and 3/4" lock nut (12) to attach lift channel (7) to front mount pump or hydraulic cylinder. Do not over tighten this assembly as it must be able to pivot.

11. Use 1/4"x1" bolt (20), 1/4" flat washer (21), 1/4" lock washer (22) and 1/4" hex nut (23) to fasten blade guides (27) to plow.
12. Return any unused items to the customer so that the vehicle can be returned to its original condition if the snowplow is removed.
13. See separate installation instructions for the hydraulic power unit, wiring and controls.

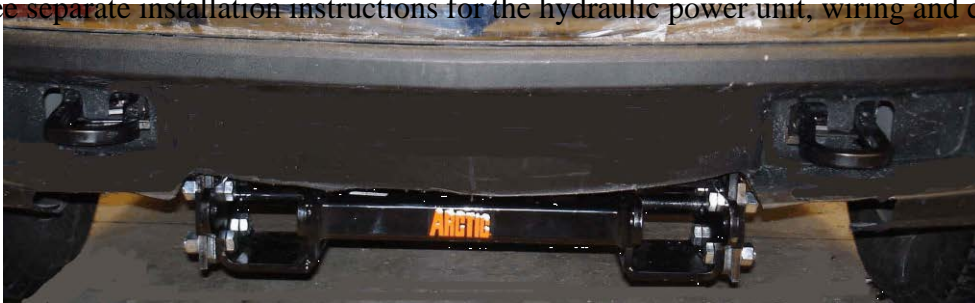

Suggested torque value for bolts				
Thread Size	Grade 5		Grade 8	
	Dry (ft. lb)	Oiled (ft.lb)	Dry (ft. lb)	Oiled (ft.lb)
¼-20	8	6	12	9
¼-28	10	7	14	11
5/16-18	17	13	24	18
5/16-24	19	15	27	21
3/8-16	31	24	44	34
3/8-24	35	27	49	38
7/16-14	49	38	70	54
7/16-20	55	42	78	60
½-13	75	58	105	82
½-20	85	65	120	90
5/8-11	150	115	210	165
5/8-18	170	130	240	185
¾-10	270	205	375	290
¾-16	295	230	420	320
7/8-9	395	305	605	455
7/8-14	435	335	670	515
1-8	590	455	905	695
1-14	660	510	1030	785

Arctic Equipment Manufacturing Corporation reserves the right under its product improvement policy to change construction or design details and furnish equipment when so altered without reference to illustrations or specifications used herein.

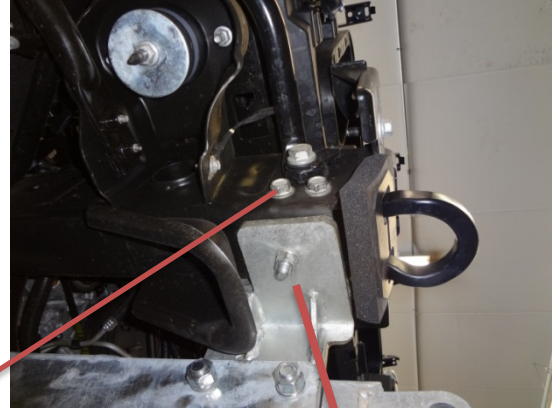
GMC/Chevy 1500, 2016

Loosen bolts that are holding tow hooks. Install mounting brackets as shown using two existing vehicle bolts on driver side and one existing vehicle bolt on curb side. Finger tighten hardware. On the bottom drill ½” hole through the vehicle frame, installing a plate inside and ½” x 1-3/4” bolt with lock washer and nut. (Be sure that mounting bracket is tight against the bottom of the vehicle frame before drilling the hole). Be sure to tight the bolt.



Drill two ½” holes (curb side – using holes in the mounting bracket as a guide) and install 2 x ½” x 1 3/4” bolts with lock washer and nut.

Loosen all nuts.

Install a mounting bracket on the driver side.

Bolt of the tow hook (inside bolt) must be turned so that a nut is facing inside.

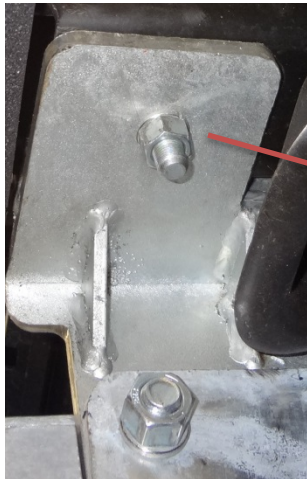

On the bottom drill 1/2" hole through the vehicle frame, installing a plate inside and 1/2" x 1-3/4" bolt with lock washer and nut. (Be sure that mounting bracket is tight against the bottom of the vehicle frame before drilling the hole). Be sure to tight the bolt.



Drill one 1/2" hole (curb side) and install 1-1/2" x 1 3/4" bolts with lock washer and nut.

Loosen all nuts.

Do not tighten any hardware until instructed to do so.

Insert the spreader bar between the mounting brackets. Insert 5/8" x 2" bolts from inside spreader bar through mounting bracket holes.



Install thrust arm (note thrust arm must be installed as shown on the picture with gusset on the top of thrust arm) to the mounting bracket using 5/8" bolt, lock washer and nut. Ensure that thrust arms are tight against cross member before drilling 17/32" hole, using 9/16" holes in thrust arm as guide. Insert 1/2" welded bolt from inside the frame, through the thrust arm. Secure using lock washers and hex nuts.

Tighten all hardware (nuts and bolts).



TECHNICAL BULLETIN

Thursday 12, July 2018

Please find the technical bulletin on the next page for Intermittent Cluster, Radio and HVAC Display resets on trucks when snowplow installed on several GM trucks.

Also find the information about how to attach blunt cut wires coming from GMC Snowplow Jumper harness to the solenoid on Page #5, 6 and 7 or [click here to navigate to these pages](#).

Basically, Red/Orange wire from the Jumper harness is attached on the solenoid (Battery Cable Plow Side) and Black wire from the Jumper harness goes to the ground (chassis). Mentioning that, dealer or a customer has to run two wires 16ga from these blunt cut wires to the solenoid and to the ground.

If you have any questions, please contact us at: (866) 757-1243 or web@arcticsnowplows.com

UI Bulletin #124h

Subject: Intermittent Cluster, Radio and HVAC Display Resets on Snow Plow Trucks

Models/Years Affected: 2014 Chevrolet Silverado 1500
2015 and beyond Chevrolet Silverado
2014 GMC Sierra 1500
2015 and beyond GMC Sierra
With Snow Plow Prep Package (RPO VYU)

Origination Date: November 30, 2015

Revision Date: January 29, 2018

ADVISORY:

Notice: GM Dealers refer to the latest version of Service Information PIT#5387 for labor code/time information

Condition/Concern:

Trucks equipped with option VYU [Snow Plow Prep] and a snow plow, may exhibit occurrences in which the Instrument Panel Cluster (IPC), Radio and HVAC displays may "blank out" or reset after changing the snow plow position. This condition is caused by a system voltage over-shoot phenomenon called 'load dump'. When the large electrical draw of the plow pump motor is suddenly removed the field energy that is built up in the alternator causes a system voltage overshoot that momentarily moves above the normal design operating levels for the module displays. As a result the displays will shut down or reset causing the momentary blank out condition. The modules are designed to do this and immediately recover. *No modules* should be replaced for this condition.

Repair/Recommendation:

Contact your local GM Dealer for an appointment to install **PN 84043394 VYU Snow Plow Jumper harness** per the latest version of **GM Service Bulletin PIT#5387**. If your truck has RPO VYU and did not come with the harness parts they may be ordered by your dealer.

Note: This jumper harness and installation will be provided [one time] without charge. Installation charges will be waived only if the jumper is installed at your GM dealer.

General Motors Upfitter Integration
<http://www.gmupfitter.com>

Installation Instructions**1) Single alternator systems:**

- a) Unplug the 2-way connector on the alternator.
- b) Identify the master alternator connector [at the very tip of the harness when it is fully extended]. Insert it in the alternator.
- c) Take the original alternator connector and plug it into the mating jumper harness connector.
Note: In this case the second alternator connector will be unused and will remain capped and tied to the harness bundle.

2) Dual alternator systems:

- a) Unplug the control connectors on both alternators.
- b) Identify the master alternator connector [at the very tip of the harness when it is fully extended]. Insert it in the 'master' alternator on the RH side of the engine.
- c) Identify the 'slave' alternator connector on the jumper harness and insert it in the LH 'slave' alternator. Insert the removed LH alternator connector into the [unwired] cap on the jumper harness.

3) All systems:**a) Service part [early] version:**

- i) Route the snow plow jumper harness along the existing harness routing where possible and secure the relay center with tie straps as shown in Details 3.1.1-3. Allow slack for engine roll and upright orientation of the relay center to prevent water intrusion/collection.

b) Factory shipped version [parts bag included with new vehicle]:

- i) Remove the harness and loose parts from the shipping bag/container. Locate the new corner brace pn 84234282 [it should be painted black but our pictures are of an unpainted part] and the nuts and bolts that will be used to attach the relay center portion of the harness.
- ii) For a complete *picture book sequence* for the installation see Details 3.2.1-7.
- iii) Route the snow plow jumper harness along the existing harness routing where possible and allow slack sufficient to secure the relay center to the [new flat] corner brace with the nuts and bolts included in the parts bag.
- iv) Remove the Radiator Air Upper Baffle and Deflector by unclipping it from the radiator.
- v) Remove and discard the LH front pencil brace as shown and install the new flat corner brace.
- vi) Attach the relay center to the corner brace and the brace top the truck as shown.

4) All systems final [signal] connection:

- a) An operating signal must be identified to operate the small relay in the jumper harness. This signal should go ON and OFF with the plow pump motor. The relay requires low power < 1 amp so most any signal will do without loading issues. The schematic shows the control terminals on the motor solenoid which is the most common connection point.
- b) Using a test lamp try various connection points on the plow control wiring to identify a signal that will illuminate the test lamp only when the motor is running.

Note:

Some plows will present hot [B+] to both motor solenoid control terminals until one side goes to ground. As long as the lamp works right the jumper can be connected the same way. Connect the blunt cut red and black wires across the same signal source as was used to operate the test lamp. Normally the red wire will go to B+ and black to ground. [If both connection points are at B+ when the motor is at rest then put the black wire to the side that goes to ground when the motor runs and the red one to the constant B+ connection.]

- c) If the operating signal must be obtained outside of the engine compartment [on the plow itself] then **two sets** of inline connector will be required. **[Order GM service kit, 2 each M 2W 19119346 and 2 each F 2W 19119765 connectors]** Using 2 sets of connectors will allow tethered caps to be fashioned for when the plow is disconnected. Secure the wires and caps appropriately to assure durability. See figure 4.

Additional Reference Information

Fig 1: Jumper harness wiring schematic

VYU Service Harness for both single and dual generator trucks

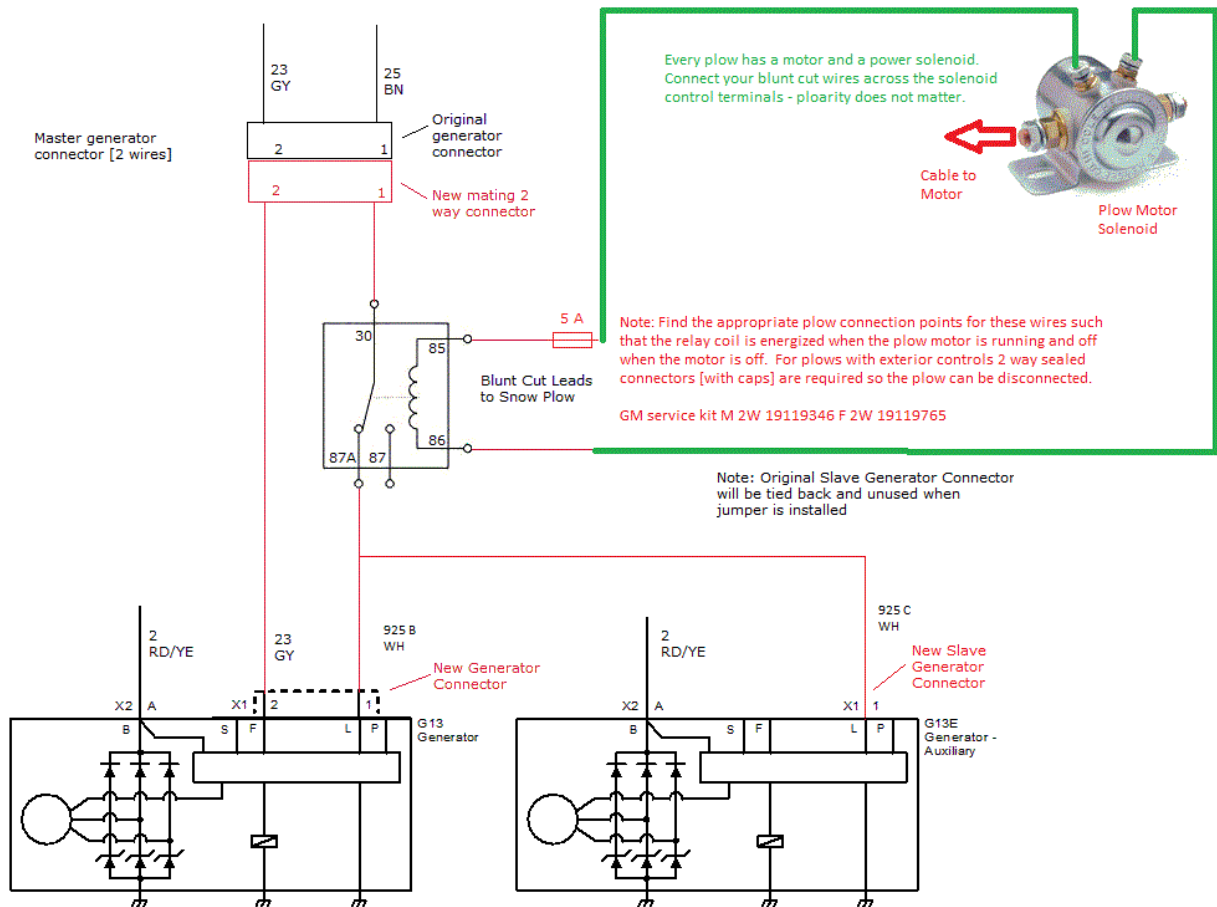

Note: To identify the signal needed by the jumper harness perform the following test. Any connection point that passes this test can be used. The best case is a signal from the wiring that remains with the truck but if that is not found then the signal must be found out on the plow itself.

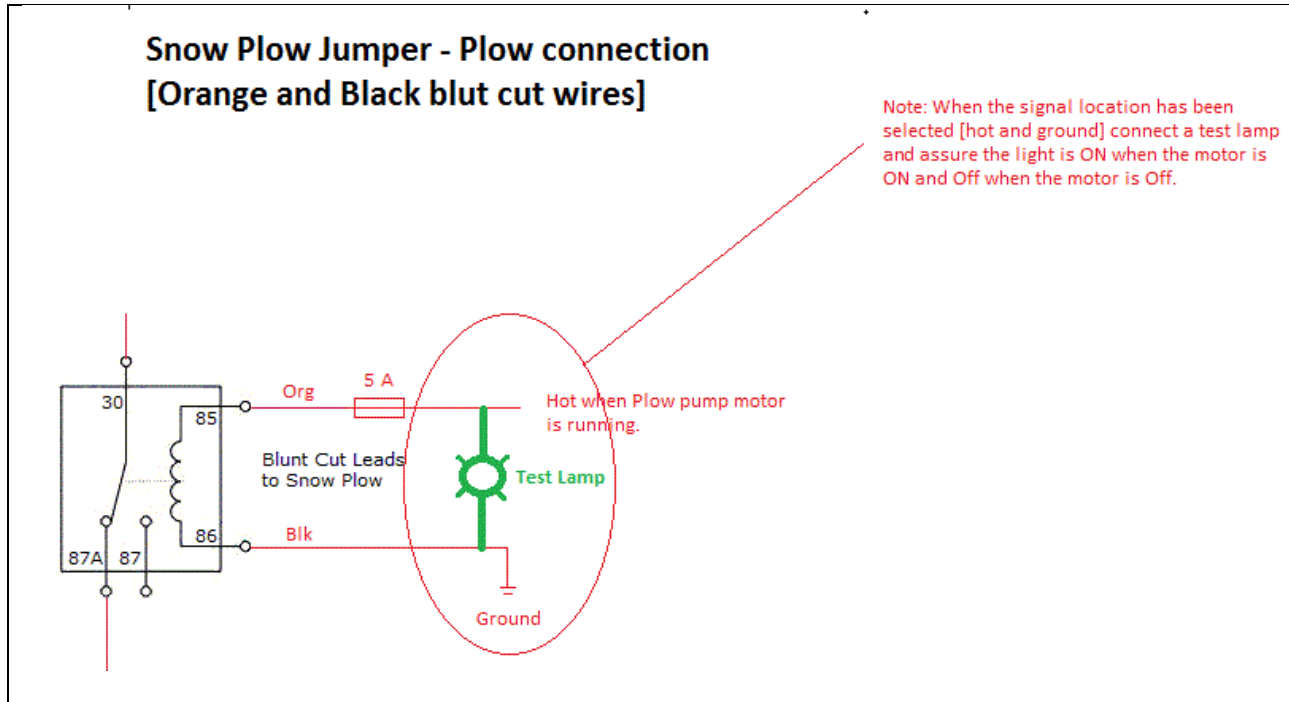

Fig: 2 Jumper Harness - Component Details

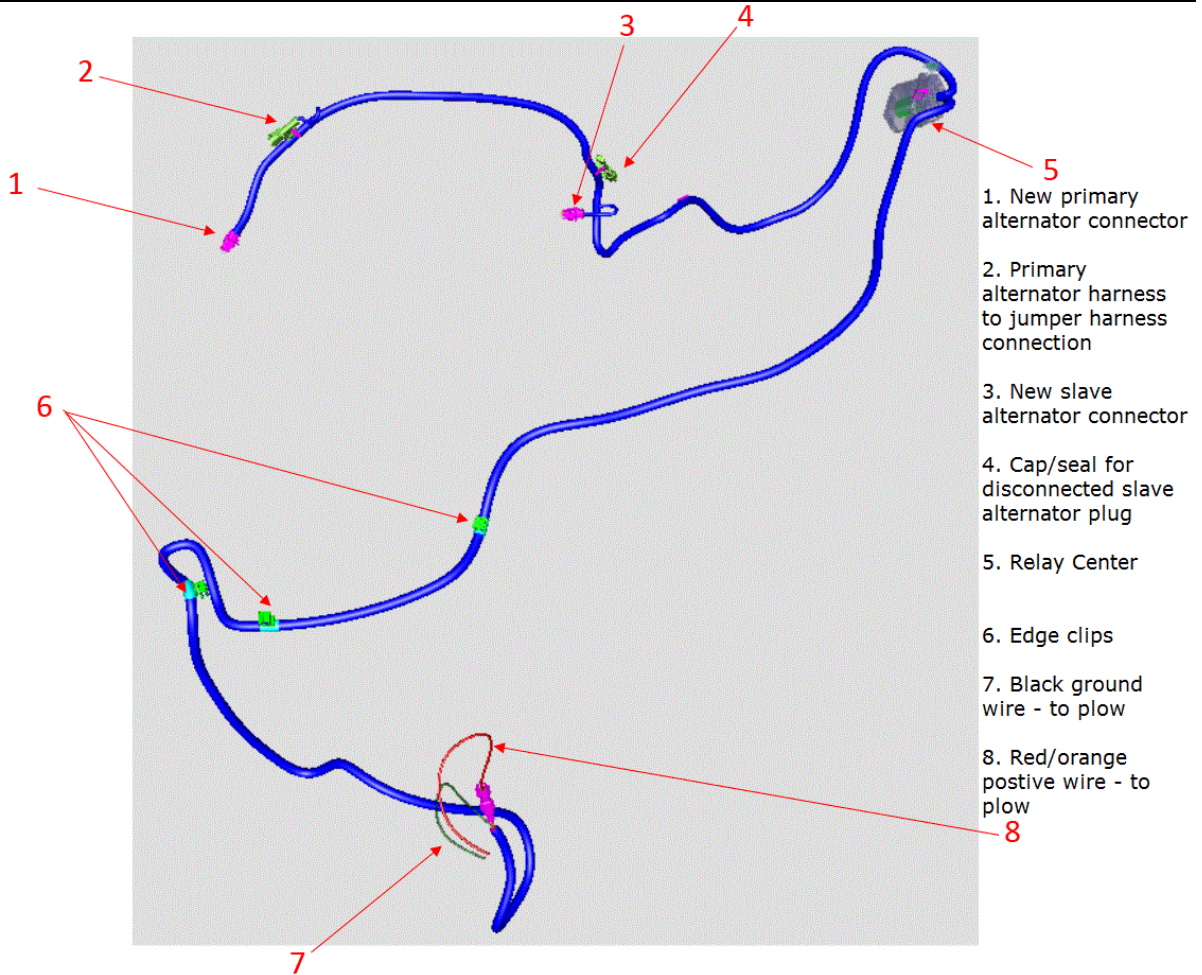

Fig: 3a Jumper Harness Layout – single alternator [see detail 3 for updated relay mounting]

VYU Single Alternator - Jumper Harness

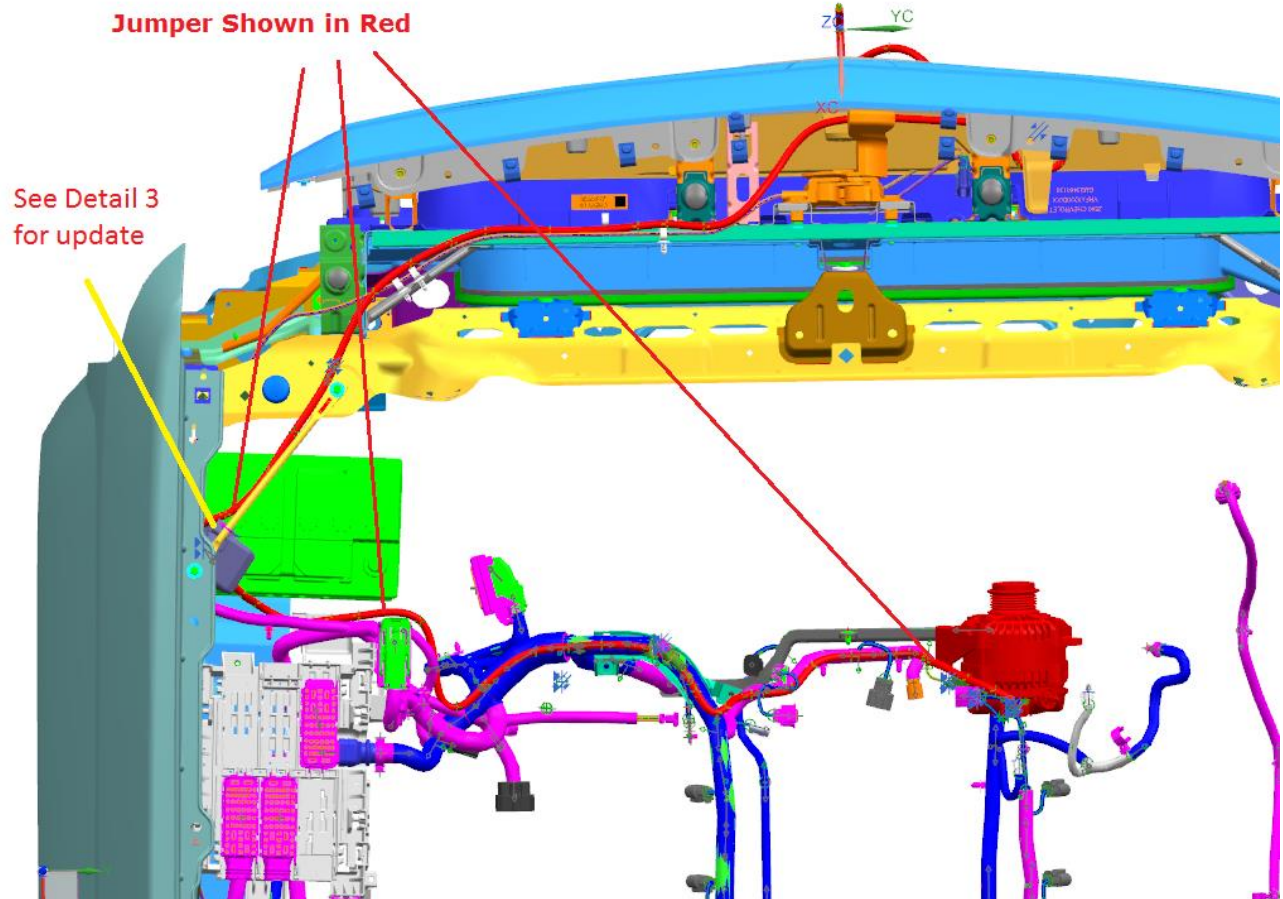
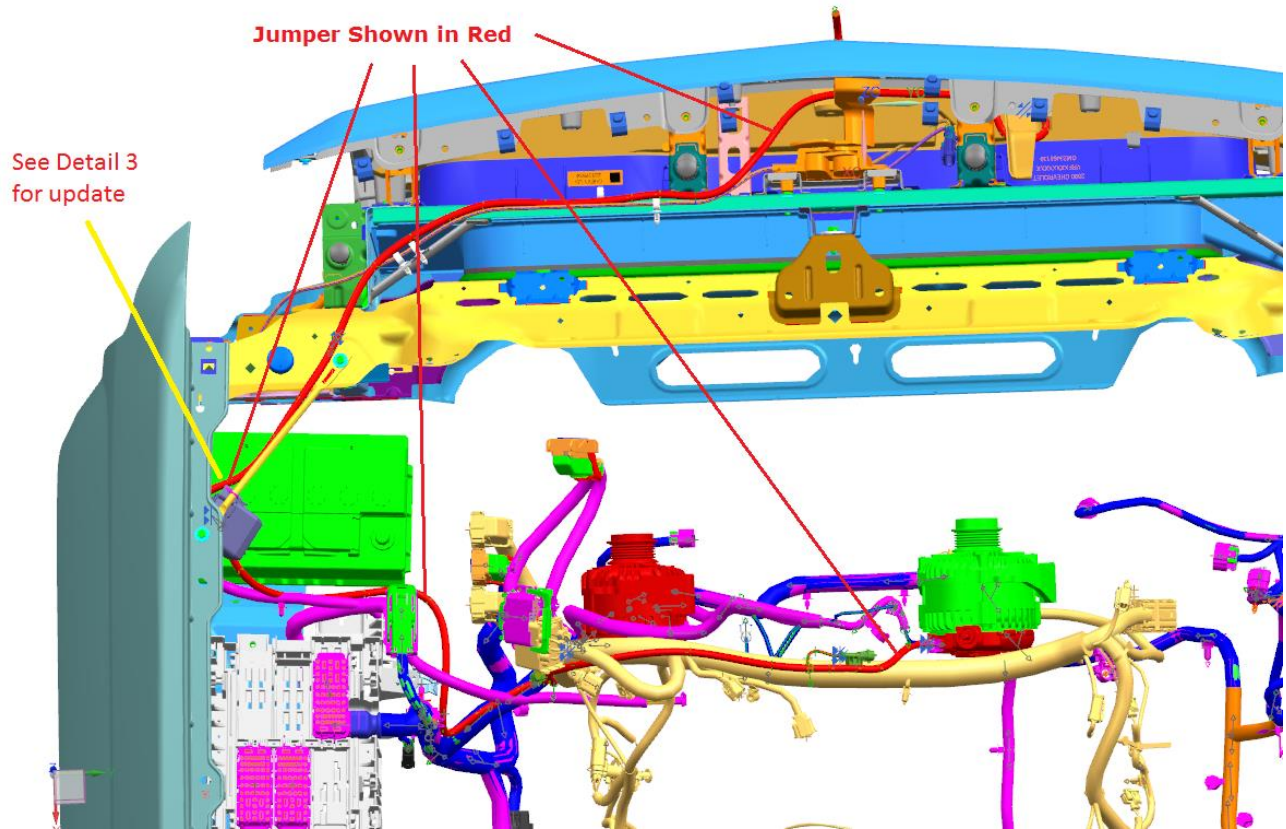

Fig: 3b Jumper Harness Layout – dual alternator [see detail 3 for updated relay mounting]

VYU Dual Alternator - Jumper Harness





Layout Details

1. Primary Alternator
2. Slave Alternator
3. Relay Center and [new] corner brace
4. Wires to plow [fused + & ground]

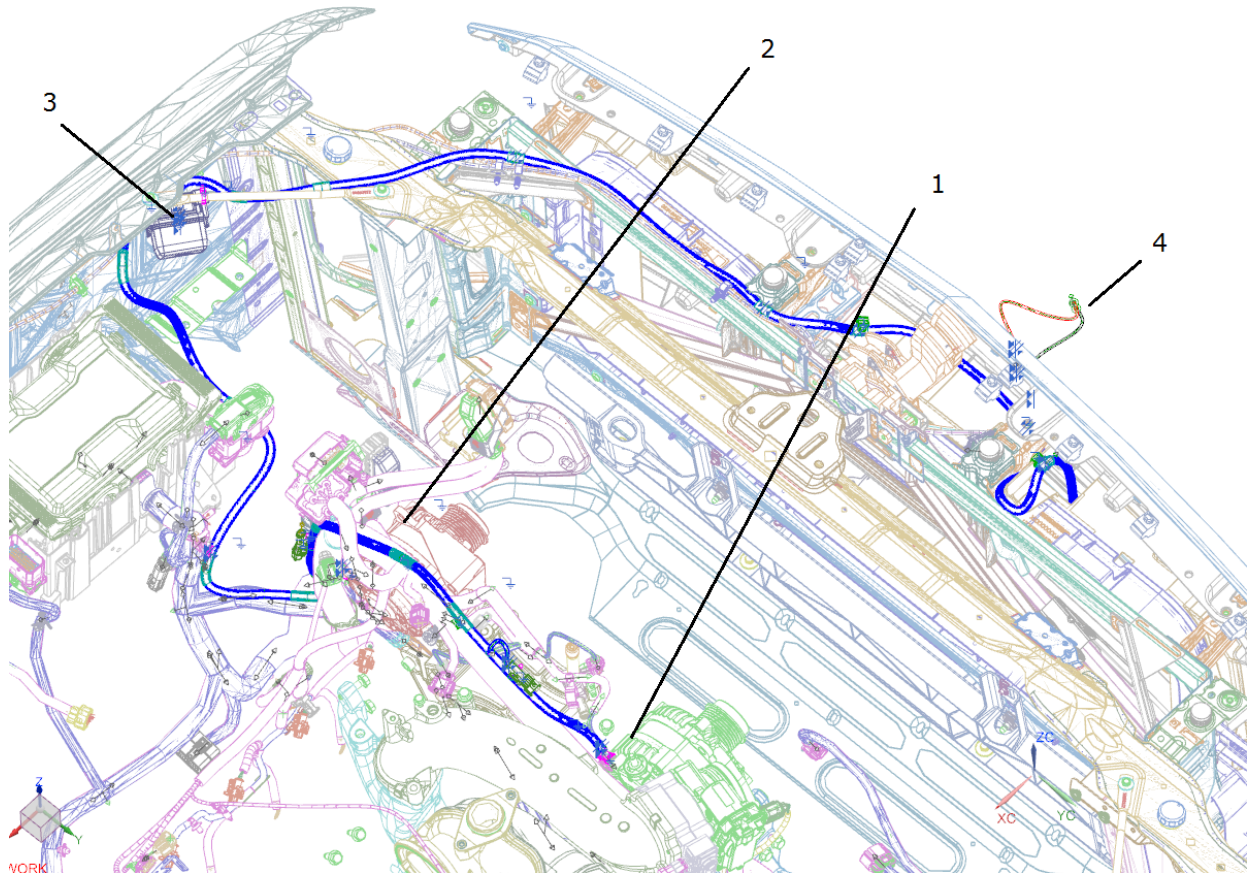

General Motors Upfitter Integration
<http://www.gmupfitter.com>

Detail 1

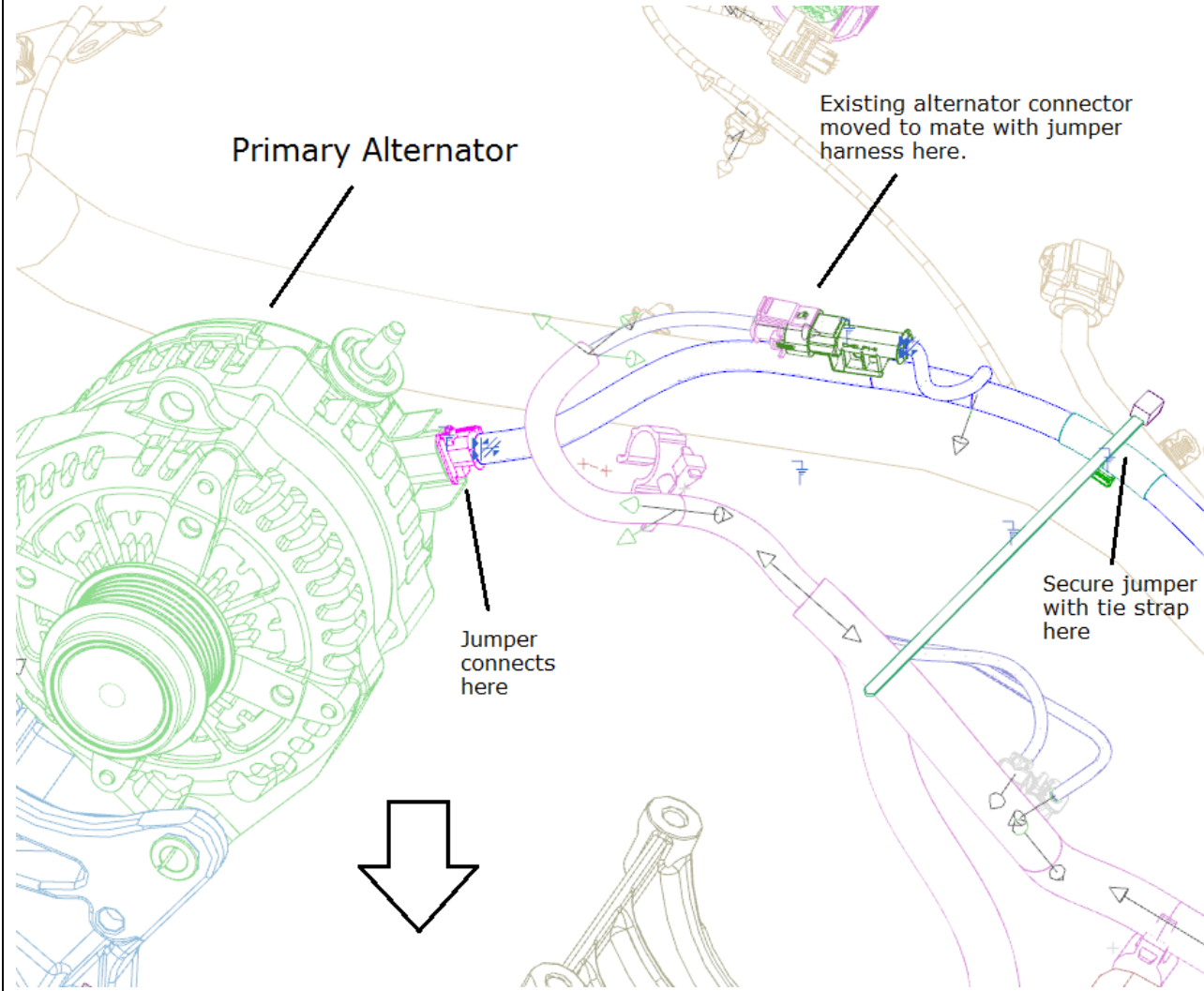

General Motors Upfitter Integration
<http://www.gmupfitter.com>

Detail 2

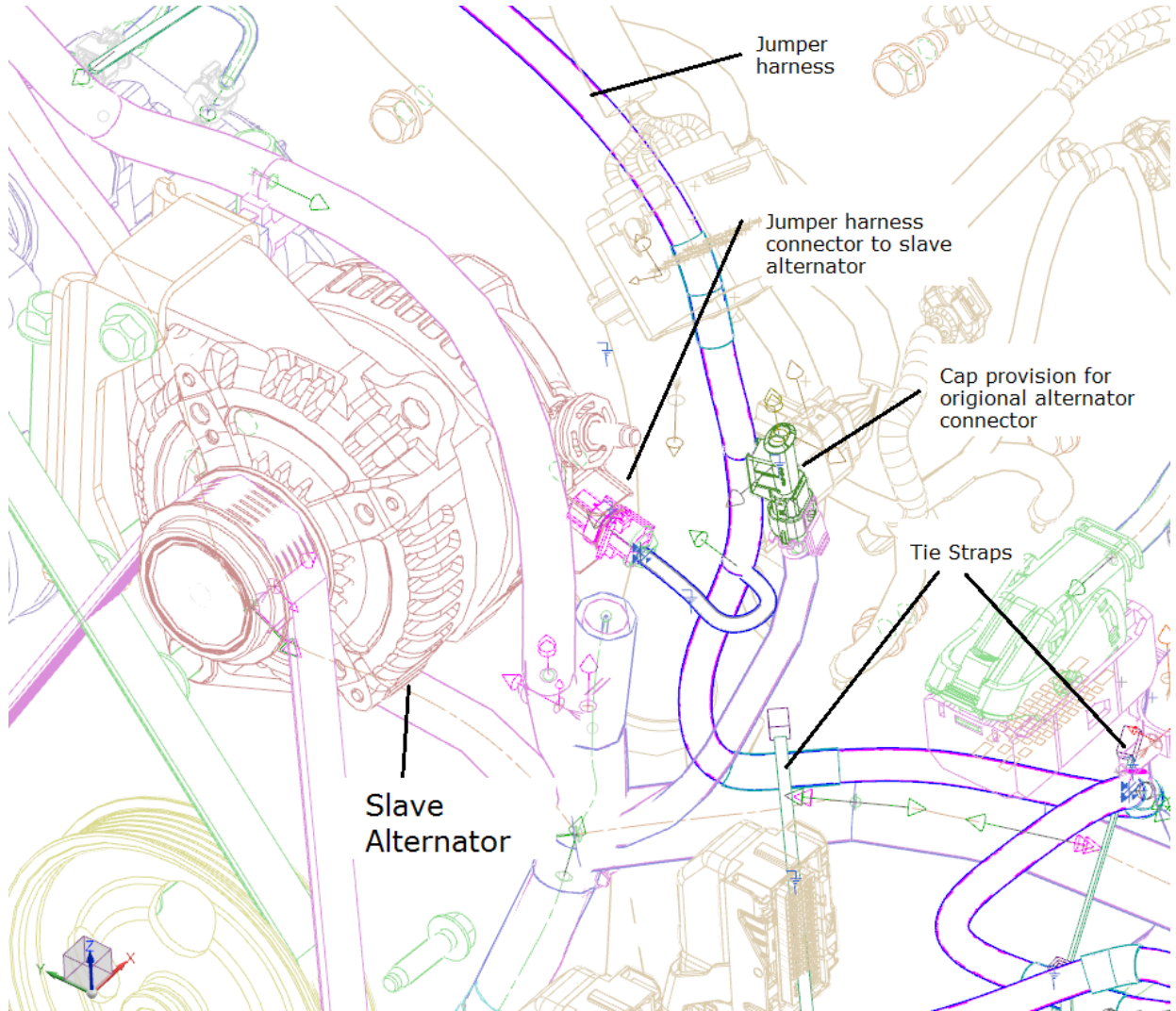

General Motors Upfitter Integration
<http://www.gmupfitter.com>

Detail 3.1.1

Details 3.1.1-3 apply to service part and not the factory included [loose shipped] part.

See Details 3.2.1-7 for the later version factory harness that comes with a new truck.

Add tie straps to relay

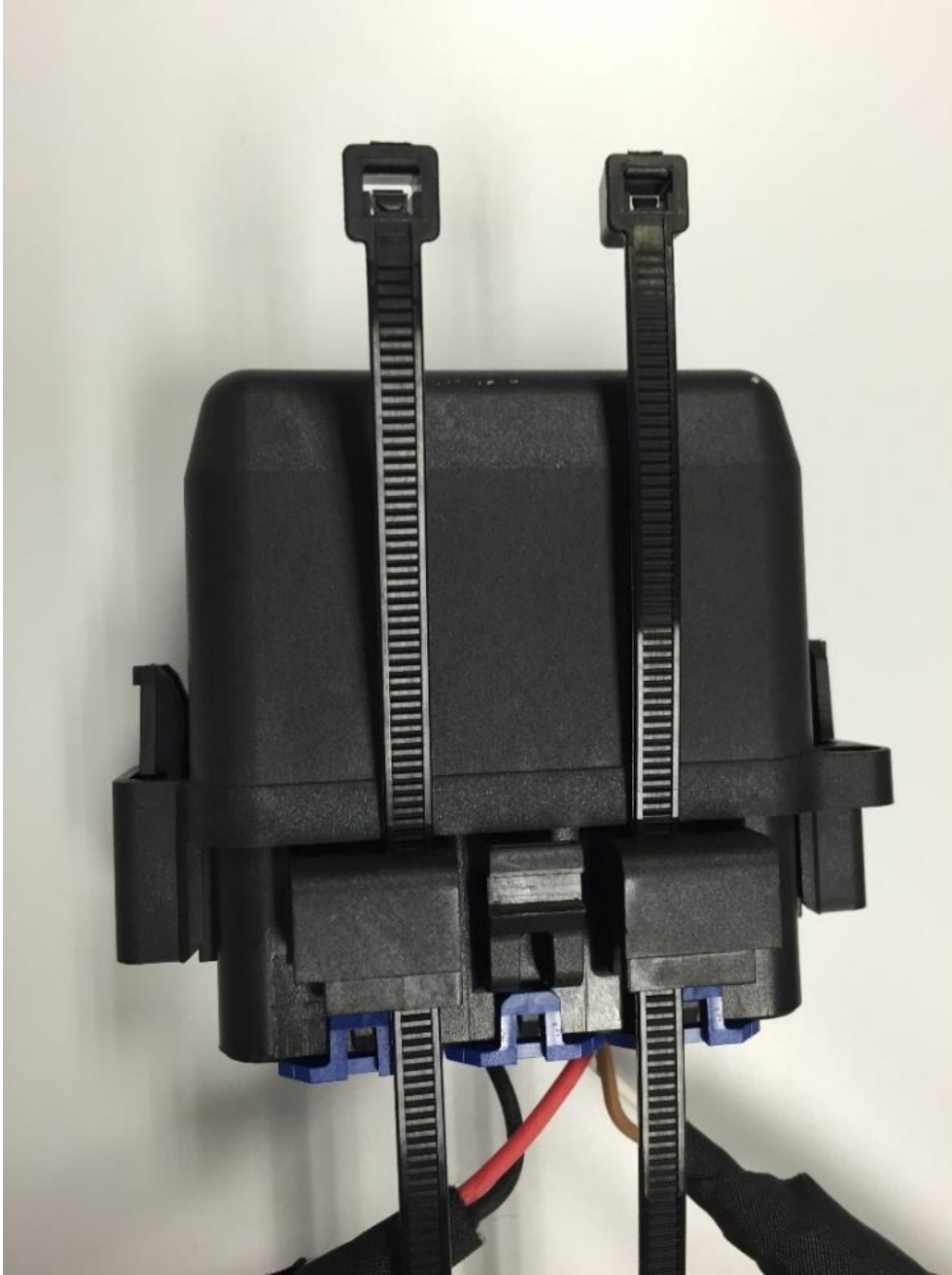

Detail 3.1.2

Single Battery Trucks

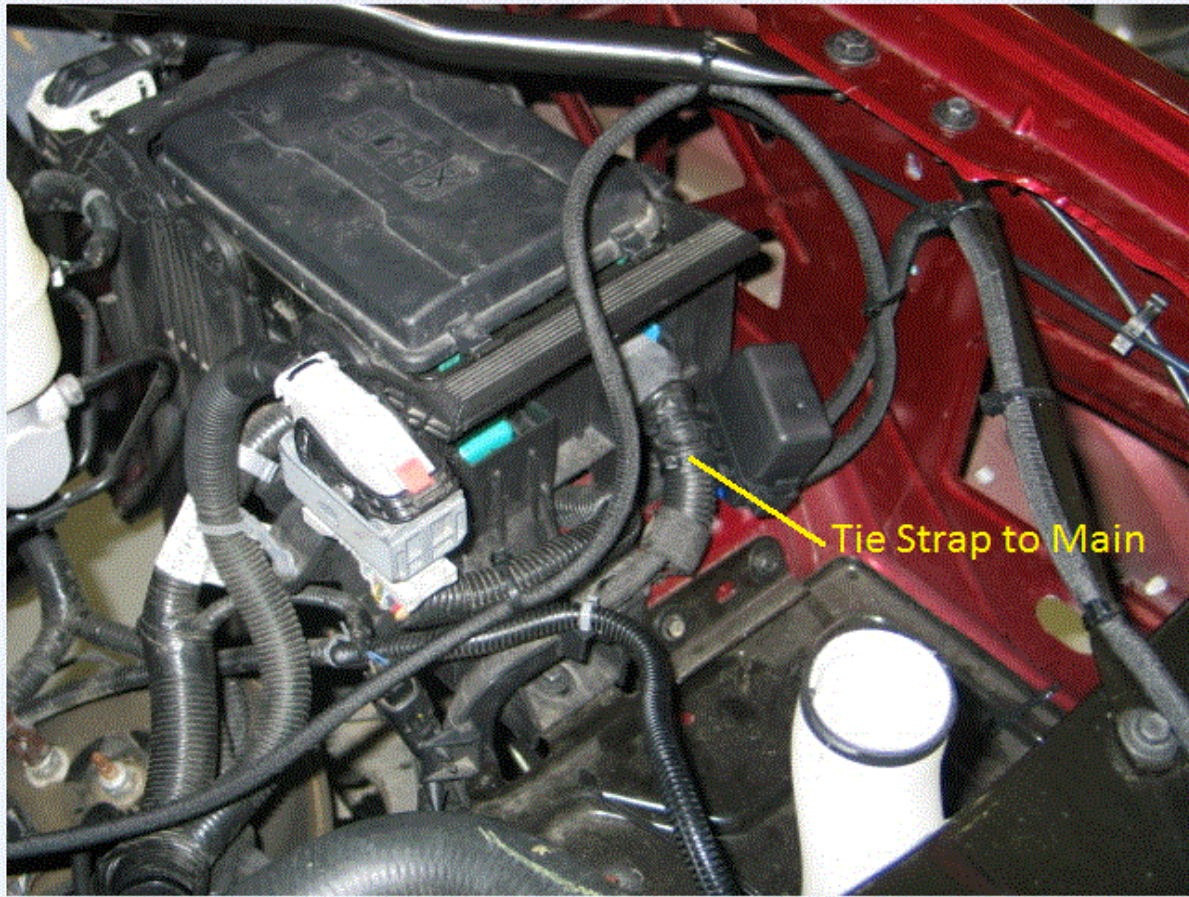

Detail 3.1.3

Dual Battery Trucks

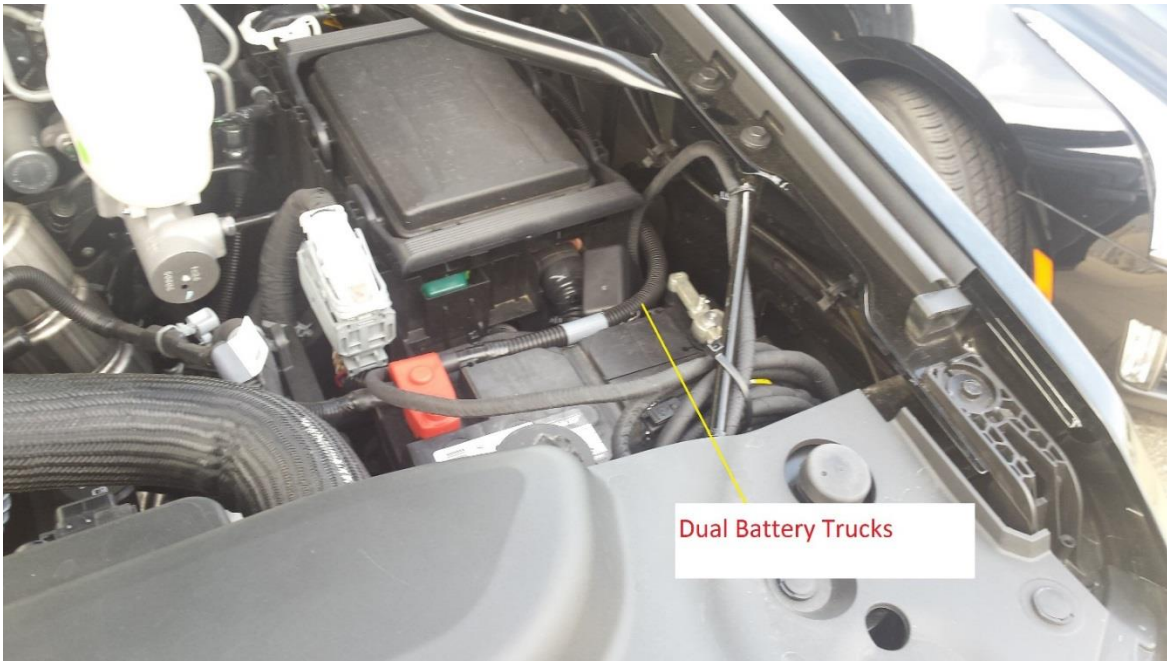

Detail 3.2.1

The following details 3.2.1 – 7 apply only to trucks that came with harness components [loose shipped] from the assembly plant.

Remove the Radiator Air Upper Baffle and Deflector.



Detail 3.2.2

Identify the new flat painted corner brace pn 84234282. [unpainted version shown]



Detail 3.2.3

Relay center and bracket details.



Detail 3.2.4

Remove the [round] left front corner brace shown here.



Detail 3.2.5

Assemble the relay bracket to the flat corner brace using hardware provided. Snap the relay bracket into the feature on the relay center.

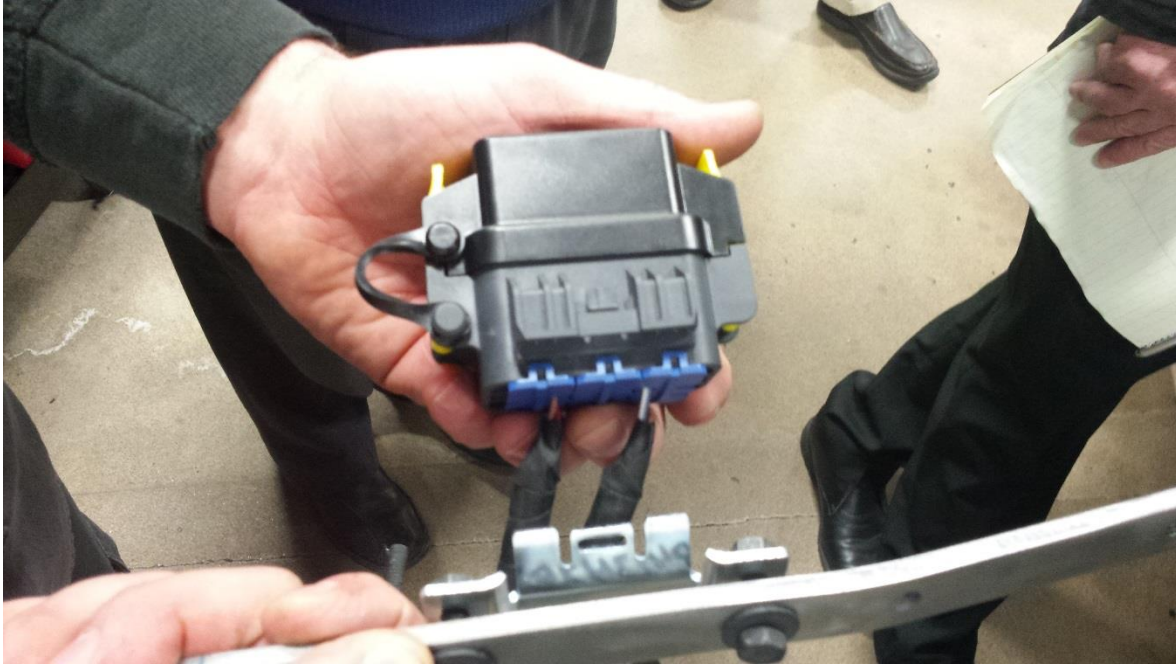

Detail 3.2.6

Position the corner brace and relay center assembly.

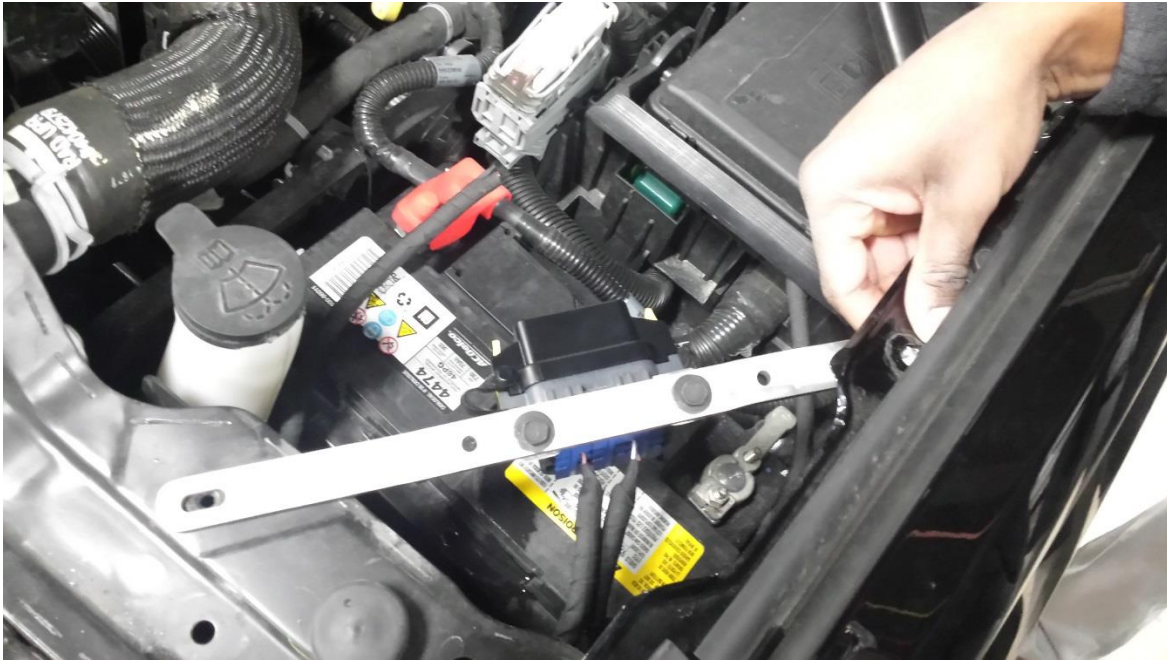

Detail 3.2.7

Mount the flat corner brace assembly as shown.

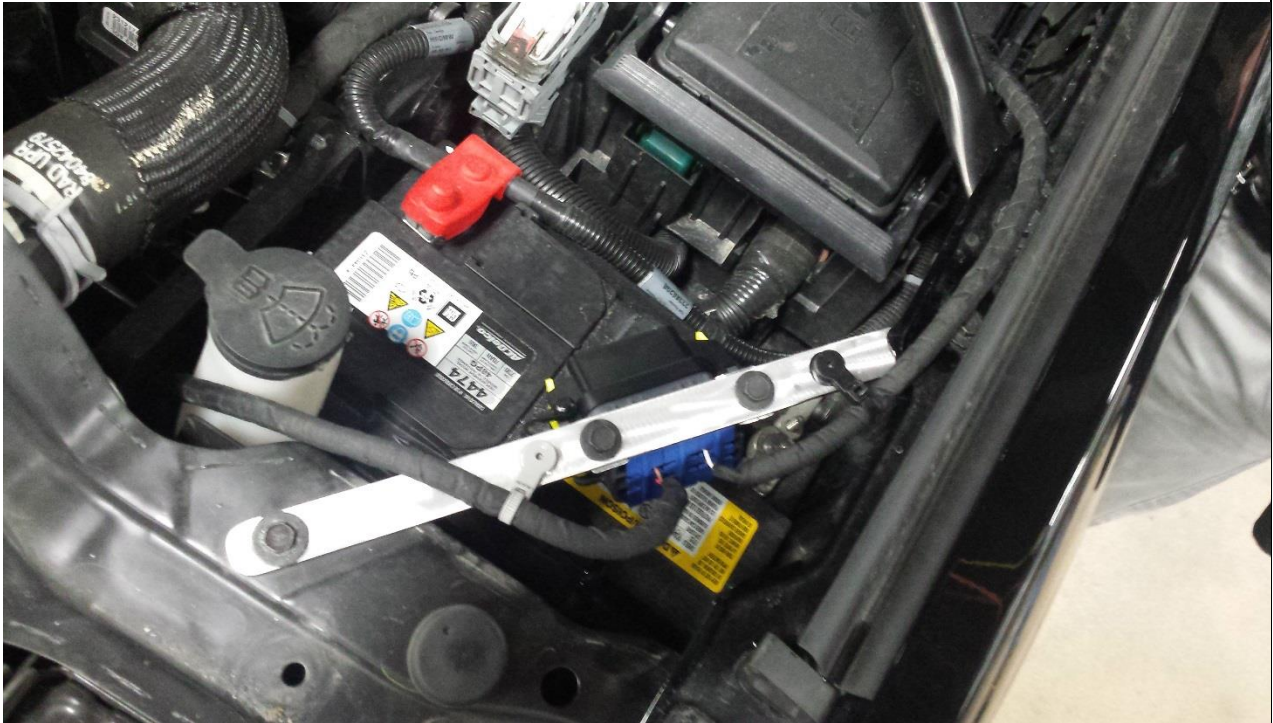

Detail 4

On units where the control signal must be obtained out on the plow wiring. **Two sets of 2-way sealed connectors** will be required as shown here. Extra mating halves can be used to fashion tethered caps. [Order GM service kit, 2 each M 2W 19119346 and 2 each F 2W 19119765 connectors]

